

2025



The Equal Chance to Win

## OFFSHORE RACING CONGRESS



2023 ORC Europeans Malta - Alex Turnbull

## ORC Championship Rules

Standard Notice of Race - Standard Sailing Instructions

Copyright © 2025 Offshore Racing Congress.

All rights reserved. Reproduction in whole or in part only  
with the permission of the Offshore Racing Congress.

# ORC Championship Regulations

---

## 1 Authority

The Offshore Racing Congress (ORC) is the international authority recognised by the World Sailing as the sole authority to administer the International Measurement System (IMS), the ORC Rating Systems (ORC International and ORC Club), the ORC Classes and the co-related regulations.

## 2 Championships

2.1 The ORC has overall authority on the Championships as follows:

- The Offshore Team World Championship
- The ORC International World and Continental Championships
- The World and Continental Championships of the ORC classes
- The ORC Double-Handed World and Continental Championship

The Offshore Team World Championship is open to National Teams to be proposed by the organizing authority occasionally and approved by the ORC Offshore Classes & Events Committee.

2.2 Except for the Offshore Team World Championship, which is held biennially, the World and Continental Championships will be held annually.

2.3 ORC may approve regional championships where participation of boats from a specific region and other neighbouring countries is expected. The use of these Championship Regulations is strongly recommended for regional and national championships.

## 3 Applications for Hosting Championships

3.1 Applications to host Championship events shall be sent to events@orc.org not later than three months before the date of the Offshore Classes and Events meeting at the AGM. The application shall be related to the championship to be organized during the second year after the AGM. Furthermore, it is strongly suggested that applicants who are contemplating the possibility of hosting future events make their intentions known to the ORC as soon as possible.

3.2 The application shall include:

- a) The name of the Organizing Authority (OA), its history of organizing past major events, with endorsement of the MNA.
- b) Venue description with explanation how to reach it, nearest international airports, accommodation possibilities available for race officials and competitors, as well as charts identifying suitable inshore and offshore racing areas.
- c) Proposed dates for the championship
- d) Outline of the financial plans for the event, expected budget and potential sponsors, with the expected number of entries.
- e) Detailed map showing shoreside facilities as follows:

### Moorings

Number of available places. A dedicated mooring place with water and electricity shall be provided for each entry, except when boats are moored on buoys.

### Offices

Following shall be provided:

- Race office - main office for registration and communication between the OA and competitors)
- Race Committee office - dedicated office for work and daily meetings of the Race Committee
- International Jury office - one room for 5-members jury or two rooms for 7-members jury that can be split in two panels.

- Technical Committee office – one room with working places for all Technical Committee members
- Press office – one room with working places for expected number of press personnel

All offices shall be equipped with broadband internet connection and office supplies.

### **Accommodation**

All committee members shall be accommodated in a minimum of 3-star accommodation with single occupancy rooms. Accommodation shall be provided as close as possible to the venue preferably within walking distance. If this is not possible, a way of transport from and to the venue shall be provided. Three meals per day shall be organized. Lunch packs are acceptable for people working on the water during race days.

### **Marina facilities**

Description of the following shall be provided:

- Sails measurements space – preferably in closed space of the area of the biggest sail in the fleet. If not possible indoor, outdoor area may be accepted with acceptable surface not damaging sails.
- Hauling, launching and repairs – crane is required for ORC Sportboat championship, while other events it may be used for repairs.
- Vehicle parking, storage and trailer parking
- Restaurant or catering facilities
- Availability of fresh water for filling reusable bottles is suggested on-site.
- Chandlery / suppliers
- Sail repair services
- Stage area for awards
- Space for sponsors & other vendors

e) Facilities afloat shall be described in types and numbers. The following is required:

### **Vessels**

- Race committee signal boat for each race area
- Pin-end mark boat for each race area
- Mark layer RIBs: at least 2 for each race area
- 2 RIBs for International Jury
- 2 RIBs for the Technical Committee
- Media and press boats: at least 1 for each race area

### **Marks**

- Marks should be suitable in size respective to the size of boats
- Robotic marks may be used.

### **Tracking system**

- Tracking system is mandatory for the offshore races and recommended for the windward/leeward races. Details of tracking system to be used shall be provided.

f) A plan of how the event organization supports and will drive sustainability standards through its events.

g) Any special features or innovations that will enhance the attraction and unique nature of the venue, format and/or event's character.

3.3 If any of items listed in 3.2 is not described in the application, the ORC may request update of the bid before it can be taken as official to be presented at the next Offshore Classes and Events committee meeting.

3.4 A pre-approval visit from an ORC representative may be required, to which the OA shall provide a complete tour of the proposed venue and a meeting with the key persons of the organization.

- 3.5 In approving an event venue, the ORC will consider the geographical location in the context of other scheduled events. Once approved, a Letter of Agreement will be drafted and signed by the ORC and the hosting authority to outline the terms of their cooperation for the event. The Letter or Agreement shall clearly state the OA's acceptance of the obligations imposed by these regulations and its commitment to conduct the Championship in full conformity with such regulations.

## **4 Organization of the Championship**

### **4.1 12 – 9 months before the championship**

Notice of Race shall be issued following ORC Standard format. Any amendments to the ORC Standard format shall be requested with an explanation for the change. The ORC shall approve the final version of the Notice of Race.

ORC will provide the host with an initial website under [orc.org](http://orc.org) with all necessary information with the following URLs: [orc.org/eventYEAR](http://orc.org/eventYEAR) that will be used as preferred URL for the promotion and marketing keeping the continuity of all ORC championships.

Event website shall be in English with the option to have translation available in the local language. The site shall have an on-line entry system from which entries may be accepted, and entry list updated upon receipt of each new entry. Entry information shall include country affiliation, sail number, boat type, owner name, skipper name, and approximate rating. A digital crew list system shall also be provided, where crew member names and their World Sailing Sailor ID's are provided. Additional entry information, such as a boat photo, team and/or skipper biography, and past race results are encouraged. There should be a protest hearing scheduling system for the jury and an online notice board with the possibility to contact all competitors and relevant committees.

All official documents shall be posted on the website as soon as they are available, preferably in html or pdf format. Race results shall also be posted online as soon as available, even if provisional and subject to revision after any protests. ORC Scorer software shall be used to provide results quickly and made available as widely as possible.

### **4.2 9 months before the event**

The composition of the committees shall be agreed between the OA and the ORC as follows:

- Race Committee: Principal Race Officer and/or Race Officers shall have experience with ORC race management and scoring. Race Committee shall include the scorer with the highest experience in the ORC scoring software and procedures.
- International Jury shall have at least 7 members (or 5 members for DH events). It shall include an ORC Representative and shall conform to RRS Appendix N. A majority of jury members, including the Chairman and the ORC Representative shall be present from the first day of measurement and inspection till the prize giving on the last day.
- Technical Committee shall be chaired by the ORC Chief Measurer or a person nominated by him and shall have a suitable number of measurers for the number of entered boats (6 members for up to 40 boats, 8 members for 40 – 60 boats, 10 members for 60 – 80 boats, 12 members for more than 80 boats). Members shall be from at least three different countries.
- The media team shall include the ORC social media manager and ORC press officer.

The OA shall collect all travel information and organize transport from and to the airport with accommodation and meals for all committee members.

### **4.2 3 months before the event**

The OA shall order from ORC standard branding materials such as:

- ORC flags to be displayed ashore
- Class flags with the ORC logo to be used at the Race Committee boats
- Class flags with the ORC logo to be used at the backstay of each racing boat
- Event measurement sail sticker with the event's logo
- ORC standard sail measurement stickers to be used for sails measured at the venue
- Medals for the Top 3 winners in each class.

#### 4.3 **2 months before the event**

Technical Q&A explaining equipment requirements and inspection procedures shall be posted on the event's website together with the safety equipment checklist.

#### 4.4 **1 month before the event**

Sailing Instructions shall be published using the Standard ORC format. Any amendments to the ORC Standard format shall be requested with an explanation. The ORC shall approve the final version of the Sailing Instructions.

#### 4.5 **Two weeks before the event**

The OA shall submit crew lists for boats entered for the Corinthian Division to be reviewed by the ORC. A reminder for submitting crew lists may be sent a few weeks before clearly indicating the deadline. Minor corrections to the Corinthian division entry lists may be done before the start of the championship, but any additional work on this should be discouraged once the event starts.

#### 4.6 **One week before the event**

The OA shall submit to the ORC entry list with the e-mail addresses of all entrants, and ORC will set up an online scheduling system for the pre-race equipment inspection.

#### 4.7 **Equipment inspections during the event**

Pre-race equipment inspection shall include:

- Sail measurements checks and stamping
- Safety equipment check
- Measurement inventory check
- Review of certificates of entered boats with spot checks on measurement recorded in the certificate.
- Sportboat championship shall include boat weighing on each boat launch.

Post-race equipment inspection on the water shall include checking on the randomly selected boats:

- the presence of event stickers on the sails on board
- the position of the items recorded in the measurement inventory
- major OSR compliance (such as the tension of the lifelines).

Post-race equipment inspection dockside shall be based on overall results in each class when selection is made as follows:

- Flotation and stability checks: 1st boat overall in each class
- Sail measurements checks: 2nd boat overall in each class
- Crew weight checks (except for DH events where crew weight check will be part of the pre-race inspection): 3rd boat overall in each class

These measurement control criteria shall be applied in the following days, except that the same boat need not be checked twice for the same item. In this case, a different check may be scheduled for that boat, and if needed, boats placed 4th, 5th, 6th etc., will be selected for the check.

Independently from its results, any boat can be checked upon a measurement protest or by the choice of the technical committee.

An official calibrated scale for crew weighing shall be made available to the crews before the races start and to the technical committee during the races.

#### 4.8 **Media requirements and guidelines**

The Media Plan, including website and communication, shall be organised closely with the ORC. The press releases prepared by the ORC or by the OA in close communication with the ORC shall be issued as follows:

- When the Notice of Race is published
- One week before the start of the championships
- Daily press release from the first to the last day of the championships

The ORC will send the press releases to an extensive international media list. Additional press releases may be sent when there is any topic that may help in promotion of the event. A link to the Press Release sign-up form shall be included on the event's website: <https://bit.ly/Subscribe-to-ORC-News>.

ORC social media channels will be provided with content updated in close communication with the OA media team before and during the event. The official event Facebook, Instagram and YouTube feed shall be the ORC channels. ORC operates a range of social media channels. They should be linked to the event website as the primary social media channels:

- Facebook: <https://www.facebook.com/offshoreracingcongress/>
- Instagram: <https://www.instagram.com/orcsailing/>
- Flickr: <https://www.flickr.com/photos/orcsailing/albums>
- YouTube: <https://www.youtube.com/@ORCsailing>

The OA shall provide:

- Professional photographer(s) team providing photos of the event for media and ORC use. ORC will publish the photos in the ORC Flickr account for the official source.
- Whenever possible, video team providing up to up to 2-minute daily highlights with interviews in English or separate interviews, plus 1-2 up to 30-second reels daily in portrait format for social media. A drone operator should be included where possible.
- Tracking system that is mandatory for the offshore races and recommended for the windward/leeward races.
- Suitable media boat for the media team(s) with access to the ORC Social Media Manager.
- Copyright-free photos from races and related events, such as the opening ceremonies, prize giving, etc. The OA media team will coordinate the social media content, photos, and video footage delivery with the ORC.

It is recommended to have a local press officer who will take care of the local and national media and local TV in the host country language.

#### 4.9 **Social events**

The following shall be provided:

- The opening ceremony
- An event where all sailors are invited - it is suggested to include a mid-week dinner or BBQ.
- A closing ceremony/prize-giving

Additionally, daily prize-giving may be offered. Social events, such as a mid-week casual party/dinner, and after-sailing food and beer, are encouraged and very popular.

The prize-giving & closing ceremony is a party for the sailors, culminating in honouring the champions. Speeches should be short and predominantly in English/or translated with adequate space and the PA system provided. The opening and closing ceremonies shall be organized in close cooperation with the ORC to follow ORC traditions and maximise attendance. It is suggested that the prize-giving format should reflect the host city/country. The overall trophies and prizes shall be discussed and agreed with ORC.

It is recommended that social events be casual. If any functions require more formal attire, this shall be indicated to all competitors well in advance.

#### 4.10. **Event branding**

The ORC is keen to encourage OA to exploit the marketing and branding opportunities of the event entirely. This may include:

- Central and contained area for sailors to congregate before and after racing with food and beverage options,
- Banners of the event and the sponsors displayed at the venue

ORC logo shall be clearly positioned in the event branding.

## **5 Disclaimer**

- 5.1 The OA is responsible for covering all costs of the event's organization including travel and accommodation for officials, ORC branding materials, race management on the water and ashore, social events, and all other items described in these regulations.
- 5.2 The ORC, including its committees and representatives, has provided these rules and recommendations in the interest of sailors but on the understanding that it cannot be held responsible for any loss, damage, injury or inconvenience arising from its policies and rulings.



# Standard Notice of Race Guide

---

*Note: Rules that applies to fully crewed championship are printed in black, those for Double Handed championship are printed in red, while rules for the Sportboat championship are printed in blue.*

[insert event name]  
[insert organizing authority]  
[insert dates from dates from measurement until the final day and closing ceremony]  
[insert location] [insert country]  
[insert event website]

## 1 Rules

1.1 The event is governed by the rules as defined in *The Racing Rules of Sailing*.

1.2 The latest version of the following rules will also apply:

- a) IMS Rules
- b) ORC Rating Systems Rules
- c) [insert class] Class Rules [for ORC Classes]
- c) ORC Sportboat Class Rules
- d) [DP] World Sailing Offshore Special Regulations (OSR) for Category 3 with following additions:
  - i) Liferaft complying with OSR Category 2 is required for the offshore races only.
  - ii) Boat's AIS shall be active from the first day of equipment inspection until the end of the event.
  - iii) Jackstays shall be mounted on the deck for the offshore races only from the moment when boats are leaving the docks. This changes OSR 4.04.
- d) [DP] World Sailing Offshore Special Regulations (OSR) for Category 3 with following additions:
  - i) Liferaft complying with OSR Category 2 is required for the offshore races only, except that OSR 4.20.3(c) shall not apply.
  - ii) Life Jackets as defined in OSR 5.01 shall be worn while a boat is afloat, except when she is made fast or moored or if the crew is below deck.
  - iii) Boat's AIS shall be active from the first day of equipment inspection until the end of the event.
  - iv) Attention is drawn to OSR 6.01.3: "When there are only two crewmembers, at least one shall have undertaken training within the five years before the start of the race in OSR 6.02 Training Topics"
- d) [DP] World Sailing Offshore Special Regulations (OSR) Appendix B. In addition, boats shall have a marine VHF transceiver as defined in OSR 3.29.5 and adequate propulsion system or support boat for towing.

1.3 Under RRS 87, ORC Rule 206 is changed as follows:

- a) All sails, including storm & heavy weather sails required by the OSR, shall have measurement stamp or sticker with all required measurements clearly readable.
- b) [DP] Each boat shall select sails to be used at the event up to the maximum numbers as defined in ORC Rule 206.1. Selected sails will be marked with event's sticker. Only sails marked with event's sticker may be on board during the event.
- c) [DP] Sails carried on board may vary from day to day but shall remain the same for each individual race day, including days with multiple races even in the case of damage to sails. The race day begins when the boat leaves for the race course from its dock or mooring.
- d) [DP] Sails damaged during the event may be repaired. Sails beyond repair may be replaced with permission of the technical committee.

*(Note: 1.3 is mandatory for ORC championships and optional for other events)*

- 1.4 Minimum crew weight as defined in ORC Rules 102.3 and 200.1(b) shall apply.
- 1.5 The navigation rules of the International Regulations for Preventing Collisions at Sea (IRPCAS) replace RRS Part 2 from sunset to sunrise (*include this if there is overnight race*).
- 1.6 A breach of RRS 56.2 shall not be grounds for protest by a boat. This changes RRS 60.1.
- 1.7 No national authority prescriptions will apply (*exceptions can be made only to the rules applying to the sailors from the host country, i.e. national sailing licence*).
- 1.8 If there is a conflict between languages the English text takes precedence.
- 1.9 Automatic and wind-vane devices for steering may be used.

## 2 Sailing Instructions

Sailing Instructions will be available for each entrant at completion of the registration formalities and may be posted earlier at **[insert website]**.

## 3 Communication

- 3.1 The online Official Notice Board (ONB) is located at **[insert website]**.
- 3.2 Communication with competitors will be through the online ONB with additional courtesy information by e-mails and/or WhatsApp. Each boat shall have at least one device connected to the internet with WhatsApp installed. On the water, the race committee will make courtesy broadcasts to competitors on VHF radio.
- 3.3 [DP] RRS 41(c) is changed as follows:
  - a) A boat shall not receive help from any outside source, except help in the form of information, which is freely available to all boats, whether or not by payment of a fee or subscription. However, this shall not include interpretation of information gathered by advice from any source not on the boat specific to the boat and her situation.
  - b) By way of an example and interpretation, downloading charts, weather and/or tidal GRIB files from subscription services, or having such information passed to the boat in its pure form, is permitted but receiving messages or information which is the result of interpretation from outside of the boat is not permitted.

## 4 Eligibility and Entry

- 4.1 Competitors shall comply with World Sailing Eligibility Code.
- 4.2 The event is open to all boats with a valid **[insert year in which championship is held]** ORC International certificate with a CDL between 8.000 and 16.400 included, complying with **[insert class for class events]** rules. The flotation date on an ORC International Certificate shall not be earlier than **[insert date which shall be 5 years prior the start of the championship]**.
- 4.2 The event is open to all boats with valid ORC DH International certificate with APH between 420.0 and 630.0 s/NM included. The flotation date on an ORC DH International Certificate shall not be earlier than **[insert date which shall be 5 years prior the start of the championship]**.
- 4.2 The event is open to all boats complying with ORC Sportboat Class Rules as follows:

Length overall LOA (m)	6.00 – 9.15
Displacement in measurement trim DSPM (kg)	< 2000
Displacement / Length Ratio DSPM / LSM0 <sup>3</sup>	< 6.00

Boats shall have a valid ORC International certificate with flotation date not earlier than **[insert date which shall be 5 years prior the start of the championship]**.

4.3 Classes are defined by the CDL, and the minimum and maximum number of entries as follows:

Class 0:  $16.400 \geq \text{CDL} > 13.550$

Class A:  $13.550 \geq \text{CDL} > 11.270$

Class B:  $11.270 \geq \text{CDL} > 9.630$

Class C:  $9.630 \geq \text{CDL} > 8.000$

*Note: The maximum number of entries per class may be agreed between the organizing authority and the ORC. In cases where the number agreed is over 50, a racing format with qualifying and final series may be devised.*

4.3 Classes are defined as follows:

Class A: APH from 418.0 – 517.9 s/NM

Class B: APH from 518.0 – 557.9 s/NM

Class C: APH from 558.0 – 630.0 s/NM

a) To assign a **[insert World or Continental]** Champion title in a class the number of boats plus the number of countries shall be not less than 14 for Classes A, B and C and less than 6 for Class 0.

*Note: For Continental Championships other than European, these restrictions may be relaxed in agreement with the organizing authority and the ORC.*

a) To assign a **[insert World or Continental]** Double Handed Champion title in a class the number of boats plus the number of countries shall be not less than 10.

*Note: For Continental Championships other than European, these restrictions may be relaxed in agreement with the organizing authority and the ORC.*

b) If the minimum number of boats in a class is not met, that class may be grouped with the closest class. In this case, the rules for awarding Championship title will be agreed by the organizing authority and the ORC and published one month before the start of the championship.

c) The person who is the owner or charterer or borrower of an entered boat shall be a national of the country the boat is representing. "National" is defined as either the holder of a passport or identity card, or a similar document stating residential status in the country represented.

d) Classes will have separate starts and separate results.

e) **Three divisions will be defined in each class based on crew gender: Male for crew made of two men, Female for crew made of two women and Mix for crew made of one man and one woman. Division results will be extrapolated from the overall results of each class.**

4.4 Any change after applying ORC rule 305.2(b) or (c) shall not change the class the boat was originally entered.

4.5 Eligible boats may pre-register until **[insert date which shall be one month to the start of the championship]** by completing the on-line registration form at **[insert website]**

4.6 To be considered as pre-registered, a boat shall complete all registration requirements and pay all fees. The list of pre-registered boats will be updated on the event website upon receipt of each new entry.

4.7 Once the entry is accepted, each boat shall submit a crew list before **[which shall be two weeks before the start of the championship]**. Crew lists shall include all crew members who will be on board at the start of the first race and may be amended up to the start of the first race. After this time, any change in the crew shall be notified to the race office.

4.7 **Once the entry is accepted, each boat shall submit crew list before [which shall be two weeks before the start of the championship]. Crew shall not be changed except in case of injury or illness and with the written permission of the technical committee.**

4.8 Each owner or skipper must personally register in the race office located in **[insert location]**, from **[insert date and time]** until **[insert date and time]**.

## 5 Entry Fee

- 5.1 The entry fee of **[insert entry fee which may vary in amounts based on class and date of payment]** per boat shall be **[insert acceptable methods of payment]** forwarded to **[insert bank details]**
- 5.2 The organizing authority is not responsible for any costs incurred by the non-acceptance of a boat's registration.

## 6 Amateur crews (Corinthian Division) and Female crews (Female Division)

- 6.1 There will be additional prizes for Corinthian and Female Divisions for a minimum of 3 entries of each division in each class. Corinthian and Female Divisions results will be extrapolated from the overall class results with boats in these division eligible for the overall class prizes as well.
- 6.2 For the Corinthian Division, the World Sailing Sailor Categorization Code shall apply, and all crew shall hold a valid Group 1 categorization. Details of the World Sailing Sailor Categorization Code and information on how to apply can be found on the World Sailing website.
- 6.3 For the Female Division a boat shall have 50% or more female competitors on board.
- 6.4 The closing date for the receipt of valid Corinthian Division or Female Division entries shall be **[which shall be two weeks before the start of the championship]**. Each entry shall include a complete crew list and show the sex, World Sailing Sailor ID and the categorization group for each crew. All crew shall hold valid categorization prior to this date that do not expire until after the final day of the event. Late entries and incomplete entries cannot be considered for this division.
- 6.5 Any crew change that will cause the boat incompliance with 6.2 and 6.3 will automatically exclude the boat from the relevant Division.
- 6.6 All crew lists will be posted on the official notice board or website as soon as possible after the registration deadline. The time limit for a protest or request for redress by a boat regarding the World Sailing's Sailors Categorization Code is **[insert date and time which shall be no later than at the end of the first day's racing]**. This changes RRS 60.3(b) and 61.2.

## 7 Advertising

- 7.1 [DP] Boats shall display advertising chosen and supplied by the organizing authority according to the World Sailing Advertising Code as follows:
- bow numbers with advertisement as forward as possible on both sides of the hull
  - advertisement to be displayed on both sides of the foremost 20% of the mainsail boom
  - class flag that shall be flown on the backstay throughout the entire event.

**[exclude any of event advertising if not used]**

- 7.2 The organizing authority may also require the installation, at no cost to competitors, of on-board video cameras and/or position devices, use of which will be defined in the Sailing Instructions.

## 8 Schedule

- Day 1, **[insert date]** - Registration and equipment inspection
- Day 2, **[insert date]** - Registration and equipment inspection
- Day 3, **[insert date]** - Registration and inspection, Practice Race, Opening Ceremony
- Day 4, **[insert date]** - Long offshore race
- Day 5, **[insert date]** - Long offshore races continued
- Day 6, **[insert date]** - Inshore race(s)
- Day 7, **[insert date]** - Inshore race(s)
- Day 8, **[insert date]** - Short offshore race.
- Day 9, **[insert date]** - Inshore race(s), Closing Ceremony

*Note: For Continental Championships, this schedule may be shortened to include two racing days for two short offshore races and three racing days for six inshore races*

- a) The long offshore race will be approximately 30-36 hours for the slowest boat.
- b) The short offshore race will be approximately 10-12 hours for the slowest boat.
- c) Inshore races will be approximately 1 to 1.5 hours.
- d) The schedule may be changed depending on the weather and wind conditions.

## 8 Schedule

- Day 1, [insert date] - Registration and equipment inspection
- Day 2, [insert date] - Registration and equipment inspection
- Day 3, [insert date] - Registration and equipment inspection, Opening Ceremony
- Day 4, [insert date] - Short offshore race
- Day 5, [insert date] - Long offshore race
- Day 6, [insert date] - Long offshore race continued
- Day 7, [insert date] - Long offshore race finished, Closing ceremony

*Note: Short offshore race is optional.*

- a) The long offshore race will be approximately 48-60 hours for the slowest boat.
- b) The short offshore race will be approximately 8-10 hours for the slowest boat.
- c) The schedule may be changed depending on the weather and wind conditions.

## 8 Schedule

- Day 1, [insert date] - Registration and equipment inspection
- Day 2, [insert date] - Registration and equipment inspection
- Day 3, [insert date] - Registration and inspection, Practice Race, Opening Ceremony
- Day 4, [insert date] - Coastal race
- Day 5, [insert date] - Inshore race(s)
- Day 6, [insert date] - Inshore race(s)
- Day 7, [insert date] - Inshore race(s), Closing Ceremony

- a) The coastal race will be approximately 5-6 hours for the slowest boat.
- b) Inshore races will be approximately 1 to 1.5 hours.
- c) The schedule may be changed depending on the weather and wind conditions.

## 9 Equipment Inspection

- 9.1 Each boat shall have [insert year in which championship is held] ORC [insert International or **DH International**] certificate issued up to [insert date which shall be one week before the start of the championship]. Certificates issued after that date may be accepted only by the request of the relevant ORC Rating office. This changes RRS 78.2.
- 9.2 No changes shall be made on ORC [insert International or **DH International**] certificates after [insert date which shall be one week before the start of the championship] unless prescribed and approved by the technical committee in correcting any error that may be found in boat's certificate before or during the pre-race equipment inspection and before the start of the first race.
- 9.3 Boats shall be available for equipment inspection from [insert date and time] until [insert date and time]. Booking of time slots for inspections by the boats will be available through the online system from [insert date which shall be one week before the start of the championship].
- 9.4 Pre-race measurement check will include boat weighing on each boat launch.
- 9.4 Measurement and rules compliance inspections will be carried out throughout the championship with emphasis on boats well placed in the scoring.
- 9.5 A boat shall not start until she passes the pre-race equipment inspection.

## 10 Venue

- 10.1 The venue for the event is **[insert description]**.
- 10.2 The offshore courses racing area will be **[insert description]**.
- 10.3 The inshore racing area will **[insert description]**.

## 11 Penalty system

- 11.1 RRS 44.1 is changed so that the Two-Turns Penalty is replaced by the One-Turn Penalty for breaking one or more rules of Part 2 in an incident outside the *Zone* while racing.
- 11.2 The intention is to appoint an international jury as provided in RRS 70.3.

## 12 Scoring

- 12.1 Eight races are scheduled including two offshore races and six inshore races. Inshore races will be windward/leeward races, except where unusual or extreme local conditions make it impossible to sail a windward/leeward course, then the organizing authority in agreement with the ORC Representative may give permission to sail a substitute course.
- 12.1 **The Low Point System will apply as defined in RRS Appendix A except that race scores will be multiplied with the scoring coefficient of 1.0 for the Coastal race and 1.5 for the long Offshore race.**
  - \* Note: Exclude this if there is no coastal race planned*
- 12.1 Eight races are scheduled including one coastal race and seven inshore races. Inshore races will be windward/leeward races, except where unusual or extreme local conditions make it impossible to sail a windward/leeward course, then the organizing authority in agreement with the ORC Representative may give permission to sail a substitute course.
- 12.2 At least 4 inshore races and 1 offshore race or at least 3 inshore races and 2 offshore races are required to be completed to constitute a series.
- 12.2 **A boat's series score shall be the total of her race scores. One race is required to constitute a series.**
- 12.2 **At least 4 races are required to be completed to constitute a series.**
- 12.3 A boat's series score shall be the total of her race scores excluding her worst score as follows:
  - a) Offshore race scores shall not be excluded
  - b) When 4 or fewer inshore races have been completed, a boat's series score will be the total of her race scores
  - c) When 5 or more inshore races have been completed, a boat's series score will be the total of her race scores excluding her worst inshore race score.
- 12.3 **When 5 or fewer races have been completed, a boat's series score will be the total of her race scores. When 6 or more races have been completed, a boat's series score will be the total of her race scores excluding her worst race score.**
- 12.4 Inshore race results will be determined by corrected times calculated by the Polar Curve Scoring and constructed course scoring method.
- 12.3 **Coastal race results will be determined by corrected times calculated by the single **[insert ToT or ToD]**, calculated by the Weather Routing as provided by the ORC. List of ratings will be published not later than 1 hour before the start.**
- 12.4 **Coastal race results will be determined by corrected times calculated by the single **[insert ToT or ToD]** calculated by the Weather Routing as provided by the ORC. List of ratings will be published not later than 1 hour before the start.**
- 12.4 **Long offshore race results will be determined by corrected times calculated by the single **[insert ToT or ToD]** calculated by the Weather Routing as provided by the ORC. List of ratings will be published not later than 1 hour before the start.**

- 12.5 Inshore race results will be determined by corrected times calculated by the single **[insert ToT or ToD]** calculated by the Weather Routing as provided by the ORC. List of ratings will be published not later than 1 hour before the start.
- 12.5 Offshore race results will be determined by corrected times calculated by the single **[insert ToT or ToD]** calculated by the Weather Routing as provided by the ORC. List of ratings will be published not later than 1 hour before the start.
- 12.6 RRS 90.3(e) shall apply.

### **13 Support person vessels**

[DP] All support person vessels shall be registered at the race office. Identification numbers will be provided by the organizing authority. These numbers shall be always visible.

### **14 Nautical charts**

The following nautical charts of the **[insert issuing authority]** are utilized as a reference in the Sailing Instructions: **[insert chart numbers]**.

### **15 Berthing**

- 15.1 **[insert description of berthing and conditions for use]**.
- 15.2 [DP] Boats shall be kept in their assigned places while they are in the harbour.

### **16 Haul-out Restrictions**

- 16.1 [DP] All boats shall be in the water on **[insert first scheduled day of registration]** until the end of the last scheduled race of the series.
- 16.1 **[DP] All boats shall be in the water after the pre-race weight check and no later than [insert time of the last scheduled day of registration] until the end of the last scheduled race of the series.**
- 16.2 [DP] Boats shall not be hauled out except for the purposes of repairing damage; and only after written permission from the technical committee. While hauled for this purpose, cleaning and polishing of the hull below the waterline will not be permitted. Appendages shall not be removed from the boat during the series.

### **17 Data Protection**

Competitors, owners, and their guests shall grant the absolute right and permission to the organizing authority and the ORC for any photography and video footage taken of persons and boats during the event, to be published and/or broadcast in any media, including but not limited to TV advertisements, whatsoever for either editorial or advertising purposes or to be used in press information.

### **18 Risk statement**

RRS 3 states: ‘The responsibility for a boat’s decision to participate in a race or to continue to race is hers alone.’ By participating in this event each competitor agrees and acknowledges that sailing is a potentially dangerous activity with inherent risks. These risks include strong winds and rough seas, sudden changes in weather, failure of equipment, boat handling errors, poor seamanship by other boats, loss of balance on an unstable platform and fatigue resulting in increased risk of injury. **Inherent in the sport of sailing is the risk of permanent, catastrophic injury or death by drowning, trauma, hypothermia, or other causes.**

Competitors participate in the event entirely at their own risk, see RRS 3 - Decision to Race. The organizing authority, **[insert club]**, **[insert national sailing federation]**, ORC, the PRO, the race committee, the international jury, the technical committee, the volunteers, and any other party involved in the organization of the event will not accept any liability for material damage or personal injury or

death sustained in conjunction with or prior to, during, or after the event. Each boat owner or his representative accepts these terms by signing the entry form.

## **19 Competitors Drones**

- 19.1 [DP] Teams or their representatives shall not fly drones over the shore facilities or over the race area during training or racing days without complying with local legislation and without prior written approval by the organizing authority.
- 19.2 The approval granted at the sole discretion of the organizing authority may impose limitations on where and when drones may fly.
- 19.3 At any time the risk and responsibility for flying any drone is with the person flying the drone and images made inside the race area shall be shared with the organizing authority, race committee or jury at reasonable request.

## **20 Insurance**

Each participating boat shall be insured with valid third-party insurance with a minimum cover of **[insert amount]** per incident or the equivalent.

## **21 Prizes**

- 21.1 The **[insert championship name]** champion title will be awarded to the best boat in each class.
- 21.2 Prizes will be awarded to the top three boats in each class and best boat in Corinthian and Female division in each class.
- 21.3 Additional prizes may be awarded at the organiser's discretion.

## **22 Further information**

For further information, please contact **[insert details]**.



# Standard Sailing Instructions Guide

---

*The notation '[NP]' in a rule of these Sailing Instructions (SIs) means that a boat may not protest another boat for breaking that rule. This changes RRS 60.1.*

## 1 Changes to Sailing Instructions

Any change to the Sailing Instructions will be posted before **[insert time]** on the day it will take effect, except that any change to the schedule of races will be posted by **[insert time]** on the day before it will take effect.

## 2 Communications with competitors

- 2.1 Notices to competitors will be posted on the official notice board.
- 2.2 On the water, the race committee intends to monitor and communicate with competitors on VHF radio channel **[insert channel]**.
- 2.3 The following communications may be made by the race committee on VHF: time checks and starting times, starting order and designation of race areas, confirmation of any visual signal displayed, courses including bearing and distance to the first mark, change of course, shortening, postponement, abandonment and other information explaining the intentions of the race committee.

Delay in the broadcast of these calls, or the order in which they are made, or any omission or failure in the transmission or reception of these, will not be grounds for a request for redress by a boat. This changes RRS 61.1(a).

## 3 Signals made ashore

- 3.1 Signals made ashore will be displayed at **[insert location]**.
- 3.2 When flag AP is displayed ashore '1 minute' is replaced with 'not less than **[insert number]** minutes' in race signal AP. This changes race signals AP.

## 4 Schedule of races

- 4.1 Times of the first warning signals are defined as follows:

**[insert day] [insert date] [insert time] [insert type of race (inshore or offshore)]**  
**[insert day] [insert date] [insert time] [insert type of race (inshore or offshore)]**  
etc ...

- 4.2 There will be no more than **[insert number, when appropriate]** races per day. Flag **[insert flag]** displayed on the Finishing line means "There will be one more race after the one in progress." The warning signal for the next race will be given one minute after lowering flag **[insert flag]** with one sound.
- 4.3 On the last schedule day of racing no warning signal will be given after **[insert time]**.

## 5 Class flag(s)

The Class flag(s) will be:

- Class 0: Yellow flag with ORC logo
- Class A: Blue flag with ORC logo
- Class B: Orange flag with ORC logo
- Class C: Green flag with ORC logo

## 6 Racing area

The racing area to be used for each class will be announced **[insert number]** hours before the start of the first race of the day

*Note: Use this SI only if there are more racing areas.*

## 7 Courses

- 7.1 **Inshore races** - The diagram in SI Addendum **[insert number]** shows the course, including the approximate angles between legs, the order in which marks are to be passed, and the side on which each mark is to be left.
- 7.2 **Offshore races** - The courses with description of the marks, positions of the starting line, finishing line and the order in which marks are to be passed, the side on which each mark is to be left will be announced no later than **[insert date and time]**.
- 7.3 No later than the warning signal, the race committee signal vessel will display the approximate compass bearing of the first leg.

## 8 Marks

- 8.1 **Inshore races** - Marks **[insert number or letter from diagram]** will be **[insert description]**. New mark as provided in instruction 11 will be **[insert description]**.
- 8.2 **Offshore races** - The race committee may set a windward mark which will be **[insert description]** to obtain a first leg to windward. If this mark is set, it will be approximately one nautical mile from the starting area. No later than the warning signal the race committee will display the approximate compass bearing from the race committee signal vessel to the windward mark together with either:
- (a) A red flag which indicates the mark shall be left to port, or
  - (b) A green flag which indicates the mark shall be left to starboard.

## 9 Obstructions

The following **[insert object(s), line(s), area(s) is (are)]** designated as (an) obstruction(s).

*Note: Use this SI only if there is an/are obstruction(s) on the course according to the RRS definition of obstruction.*

## 10 The Start

- 10.1 Races will be started in the following class order: **[insert class]**, **[insert class]**. The warning signal of the following class will be displayed at the earliest at the starting signal for the previous class and may also be given while other classes are still racing.
- Note: Use this SI only if the fleet is divided in more classes.*
- 10.2 The starting line is between **[insert description]** at the starboard and **[insert description]** at the port-end.
- 10.3 [DP] Boats whose warning signal has not been made shall avoid the starting area during the starting sequence for other races.
- Note: Use this SI only if there are more classes using same starting line.*
- 10.4 If any part of a boat's hull is on the course side of the starting line at her starting signal and she is identified, the race committee will attempt to broadcast on VHF her sail number, bow number or the name of the boat. Delay in the radio broadcast of these calls, or the order in which they are made, or any omission or failure in the transmission or reception of these, will not be grounds for a request for redress by a boat. This changes RRS 61.1(a).

- 10.5 A boat that does not start within **[insert number]** minutes in the inshore races and **[insert number]** minutes in the offshore race(s) after her starting signal will be scored Did Not Start without a hearing. This changes RRS A5.1 and A5.2.

## 11 Change of the next leg of the course

**Inshore races** - To change the next leg of the course, the race committee will lay a new mark and remove the original mark as soon as practicable. If mark 1 is replaced by a new mark, mark 1A will not be replaced and will no longer be a mark of the course for boats after rounding the new mark. When in a subsequent change a new mark is replaced, it will be replaced by an original mark except that mark 1A will not be replaced.

## 12 The Finish

- 12.1 **Inshore races** - The finishing line will be between **[insert description]** and **[insert description]**.
- 12.2 **Offshore races** - The finishing line will be between **[insert description]** and **[insert description]**.
- 12.3 [DP] Boats that finish by night shall illuminate their numbers when finishing, and in case of doubt shall try to identify themselves to the race committee after finishing.
- 12.4 [DP] If the race committee is absent when a boat finishes, she shall report her finishing time, and her position in relation to nearby boats, to the race committee at the first reasonable opportunity.

## 13 Time Limit

- 13.1 **Inshore races:** The Race Time Limit (see RRS 35) will be 2 hours after the starting signal. The Finishing Window is the time for boats to finish after the first boat sails the course and finishes and will be **[insert number calculated as in note below]**.

*Note: Finishing Window shall be calculated using the Time Allowances (TA) for windward/leeward course at 6 kts of wind for the slowest and the fastest boat in a class as follows:*

$$\text{Finishing Window} = 180 \cdot \frac{TA_{\text{slowest boat}} - TA_{\text{fastest boat}}}{TA_{\text{fastest boat}}} \text{ (minutes)}$$

- 13.2 **Long offshore race:** The time limit for each class is 36 hours after the starting time of the respective class. However, if the first boat in each class finishes in 30 hours or more, then the time limit for all other boats in that class is extended to 42 hours.
- 13.3 **Short offshore race:** The time limit for each class is 12 hours after the starting time of the respective class. However, if the first boat in each class finishes in 10 hours or more, then the time limit for all other boats in that class is extended to 14 hours.
- 13.2 **Coastal race:** The time limit for each class is 6 hours after the starting time of the respective class. However, if the first boat in each class finishes in 5 hours or more, then the time limit for all other boats in that class is extended to 8 hours.
- 13.2 The time limit for each class is **[insert number]** hours after the starting time of the respective class. However, if the first boat in each class finishes in **[insert number]** hours or more, then the time limit for all other boats in that class is extended to **[insert number]** hours.

*Note: Time limits shall be calculated based on the length of the course and expected duration of the race.*

- 13.3 Boats failing to finish within the Finishing Window (for inshore races) or their time limit (for offshore races), and not subsequently retiring, penalized, or given redress, will be scored Time Limit Expired (TLE) without a hearing. A boat scored TLE will receive the points of the last boat that finished within its time limit plus one. This changes RRS 35, A5.1, A5.2 and A10.

## 14 Hearing requests

14.1 *Inshore races* - For each class, the protest time limit is **[insert number]** minutes after the last boat in that class finishes the last race of the day or the race committee signals no more racing today, whichever is later. The time will be posted on the official notice board.

*Offshore races* - For each class, the protest time limit is **[insert number]** minutes after protestor's finish or the race committee signals no more racing today, whichever is later. If a boat finishes between **[insert time and date]** and **[insert time and date]** her protest time limit is extended to 09.00 on **[insert date]**.

14.2 Hearing request forms are available from the race office at **[insert URL or location]**.

14.3 Notices to inform competitors of hearings in which they are parties or named as witnesses will be posted

a) *Inshore races* - no later than 30 minutes after the protest time limit

b) *Offshore races* - within 30 minutes of the finish of all the boats involved in the protest, except those notices will not be posted from **[insert day and date of offshore race]** at **[insert time]** until **[insert day and date of offshore race]** at **[insert time]**.

Hearings will be held in the protest room, located at **[insert description]**.

## 15 Scoring

The decision on the scoring method and scoring parameters used will be at the sole discretion of the race committee and together with length of course, directions of leg and the wind direction and speed will not be grounds for request for redress by a boat. This changes RRS 61.1(a).

## 16 Safety regulations

16.1 [DP], [NP] A boat that retires from a race shall notify the race committee at the first reasonable opportunity.

16.2 [DP], [NP] A boat not intending to race shall inform the race office before the scheduled warning signal.

16.3 [DP] Any use of the engine for propulsion purposes for rescuing people, giving help or any other reason shall be reported after arrival in written form to the race committee stating the reasons for such procedure. If a boat does not gain a significant advantage in the race, the international jury may impose a discretionary penalty.

## 17 Replacement of crew or equipment

17.1 [DP] Any crew changes (adding new crew members, replacing or disembarking crew members) shall be notified to the race office no later than **[insert number]** hours before the scheduled time of the start of the first race of the day. Crew changes will be automatically approved provided that:

a) Crew members registered for the first race on a boat shall not be aboard any other competing boat throughout the remainder of the series.

b) The weight of all crew members on board after all crew changes shall not be greater than the maximum and smaller than the minimum as defined in ORC Rule 200.1.

17.2 [DP] Substitution of damaged or lost equipment is not allowed unless authorized in writing by the technical committee. Requests for substitution shall be made to the committee at the first reasonable opportunity, which may be after the race.

## 18 Equipment and measurement checks

18.1 A boat or equipment may be inspected at any time for compliance with the class rules, notice of race and sailing instructions.

18.2 [DP] When instructed by a race official on the water, a boat shall proceed to a designated area for inspection.

## **19 Official vessels**

- 19.1 Official vessels will display an **[insert flag]**. Failure of any official boat to display her flag will not be grounds request for redress by a boat. This changes RRS 61.1(a).
- 19.2 Vessels used by press, photographers, film crews, VIPs etc. are not under the jurisdiction of the race committee. Any action by these boats shall not be ground for request for redress by a boat. This changes RRS 61.1(a).

## **20 Support person vessels**

[DP] Support person vessels shall keep well clear of the starting area and, after the preparatory signal, are not to approach within 100 meters of any competing boat. A breach of this SI may result with a scoring penalty against the boat connected and/or withdrawal of permission to be in the racing area for one or more days.

## APPENDIX 1 - BOW NUMBERS

[DP], [NP] Bow numbers shall be placed as forward as possible

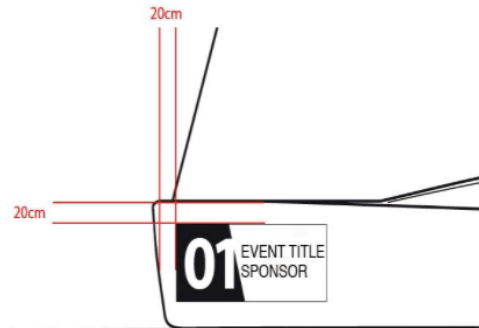
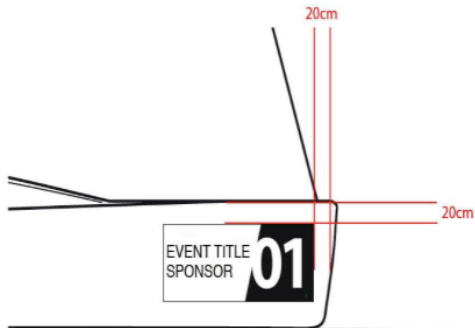

**CORRECT**



**NOT CORRECT**



## APPENDIX 2 – HEAT RACING SYSTEM

If more than [insert number] boats are entered in a Class, heat racing system will be applied as follows:

### 1. GENERAL

- 1.1 An event consists of a Qualifying Round and a Final Round. Each race in each round consists of two heats: Yellow and Blue in the Qualifying Round and Golden and Silver in the Final Round. Heats should have the same number of boats. However, in case of odd total number of boats there will be one boat more in Yellow heat in the Qualifying Round and one boat more in the Golden Fleet in the Final Round.
- 1.2 Boats will be assigned to the heats in Qualifying Round for each racing day, while for the Final Round they will stay in same heats to the end of event.

### 2. QUALIFYING ROUND

- 2.1 The Qualifying Round is planned for:

[insert date] Long offshore race  
[insert date] Long offshore race continued  
[insert date] Inshore races  
[insert date] Inshore races

At the end of the Qualifying Round boats will be assigned to the Gold and Silver Fleets in the Final Round.

- 2.2 If less than 2 inshore races are completed in the Qualifying Round, the Qualifying Round will continue up to the end of the event and there will not be Final Round (2.3 and 3 will not apply).
- 2.3 The Final Round is planned for:

[insert date] Short offshore race  
[insert date] Inshore races

- 2.4 Boats will be assigned to the heats in the Qualifying Round as follows:

- a) For the race 1 (long offshore race) boats will be sorted by their CDL and heats will be assigned to the sorted list as: Yellow, Blue, Yellow, Blue etc ...
- b) For all races on a day after the long offshore race boats will be assigned to the heats based on the long offshore race results as shown in table below, where the letters refer to the previous heat, and the number the boat's place in previous heat (in case of a tie for a place in a heat, boats will be sorted according to the national letters and sail numbers)

<i>Yellow</i>	<i>Blue</i>
<i>Yellow 1</i>	<i>Blue 1</i>
<i>Blue 2</i>	<i>Yellow 2</i>
<i>Yellow 3</i>	<i>Blue 3</i>
<i>Blue 4</i>	<i>Yellow 4</i>
<i>Yellow 5</i>	<i>Blue 5</i>
<i>Blue 6</i>	<i>Yellow 6</i>

*Etc ...*

- c) For all races on a day after b) has been applied boats will be sorted by the overall results with all completed races up to the end of previous day and heats will be assigned to the sorted list as Yellow, Blue, Yellow, Blue, etc...

### **3. FINAL ROUND**

At the completions of the Qualifying Round, overall results will be produced based on which boats will qualify for Golden and Silver heats in Final Round.

Any change to the results after applying ORC rule 305.2(b) or (c) or 305.3 after at least one race is completed in the Final Round shall not change composition of the Golden and Silver heats.

For example: In an event with 71 boats, Qualifying Round heats will be composed of 36 (yellow) and 35 (blue). After the Qualifying Round, boats placed in overall results 1-36 will qualify for the Golden Heat in the Final Round and will compete for places 1-36 to the end of event, while boats placed in overall results 37-71 will qualify for the Silver Heat in the Final Round and will compete for places 37-71 to the end of event.

*Note: Scoring is the same for all heats. This means that a boat in Final Round Silver Heat at the end of the event can have fewer points than another boat in the Golden Heat, but as per above the boat in Silver Heat cannot be placed above 37<sup>th</sup> place.*

### **4. SCORING**

RRS Appendix A shall apply for all heats in Qualifying and Final Rounds.

### **5. HEAT IDENTIFICATION**

While racing boat shall display a coloured ribbon corresponding to the heat to which she has been assigned. The coloured ribbon shall be tied to the back stay. The coloured ribbons will be issued at the race office and if the ribbon is lost or damaged spares will be available at the race office.