



2025

The Equal Chance to Win

# OFFSHORE RACING CONGRESS



©2025 ORC. All rights reserved. Malta - Alex Timboul

## Standard Sailing Instructions

# Standard Sailing Instructions Guide

---

*The notation '[NP]' in a rule of these Sailing Instructions (SIs) means that a boat may not protest another boat for breaking that rule. This changes RRS 60.1.*

## 1 Changes to Sailing Instructions

Any change to the Sailing Instructions will be posted before **[insert time]** on the day it will take effect, except that any change to the schedule of races will be posted by **[insert time]** on the day before it will take effect.

## 2 Communications with competitors

- 2.1 Notices to competitors will be posted on the official notice board.
- 2.2 On the water, the race committee intends to monitor and communicate with competitors on VHF radio channel **[insert channel]**.
- 2.3 The following communications may be made by the race committee on VHF: time checks and starting times, starting order and designation of race areas, confirmation of any visual signal displayed, courses including bearing and distance to the first mark, change of course, shortening, postponement, abandonment and other information explaining the intentions of the race committee.

Delay in the broadcast of these calls, or the order in which they are made, or any omission or failure in the transmission or reception of these, will not be grounds for a request for redress by a boat. This changes RRS 61.1(a).

## 3 Signals made ashore

- 3.1 Signals made ashore will be displayed at **[insert location]**.
- 3.2 When flag AP is displayed ashore '1 minute' is replaced with 'not less than **[insert number]** minutes' in race signal AP. This changes race signals AP.

## 4 Schedule of races

- 4.1 Times of the first warning signals are defined as follows:

**[insert day] [insert date] [insert time] [insert type of race (inshore or offshore)]**  
**[insert day] [insert date] [insert time] [insert type of race (inshore or offshore)]**  
etc ...

- 4.2 There will be no more than **[insert number, when appropriate]** races per day. Flag **[insert flag]** displayed on the Finishing line means "There will be one more race after the one in progress." The warning signal for the next race will be given one minute after lowering flag **[insert flag]** with one sound.
- 4.3 On the last schedule day of racing no warning signal will be given after **[insert time]**.

## 5 Class flag(s)

The Class flag(s) will be:

- Class 0: Yellow flag with ORC logo
- Class A: Blue flag with ORC logo
- Class B: Orange flag with ORC logo
- Class C: Green flag with ORC logo

## 6 Racing area

The racing area to be used for each class will be announced **[insert number]** hours before the start of the first race of the day

*Note: Use this SI only if there are more racing areas.*

## 7 Courses

- 7.1 **Inshore races** - The diagram in SI Addendum **[insert number]** shows the course, including the approximate angles between legs, the order in which marks are to be passed, and the side on which each mark is to be left.
- 7.2 **Offshore races** - The courses with description of the marks, positions of the starting line, finishing line and the order in which marks are to be passed, the side on which each mark is to be left will be announced no later than **[insert date and time]**.
- 7.3 No later than the warning signal, the race committee signal vessel will display the approximate compass bearing of the first leg.

## 8 Marks

- 8.1 **Inshore races** - Marks **[insert number or letter from diagram]** will be **[insert description]**. New mark as provided in instruction 11 will be **[insert description]**.
- 8.2 **Offshore races** - The race committee may set a windward mark which will be **[insert description]** to obtain a first leg to windward. If this mark is set, it will be approximately one nautical mile from the starting area. No later than the warning signal the race committee will display the approximate compass bearing from the race committee signal vessel to the windward mark together with either:
  - (a) A red flag which indicates the mark shall be left to port, or
  - (b) A green flag which indicates the mark shall be left to starboard.

## 9 Obstructions

The following **[insert object(s), line(s), area(s) is (are)]** designated as (an) obstruction(s).

*Note: Use this SI only if there is an/are obstruction(s) on the course according to the RRS definition of obstruction.*

## 10 The Start

- 10.1 Races will be started in the following class order: **[insert class]**, **[insert class]**. The warning signal of the following class will be displayed at the earliest at the starting signal for the previous class and may also be given while other classes are still racing.

*Note: Use this SI only if the fleet is divided in more classes.*
- 10.2 The starting line is between **[insert description]** at the starboard and **[insert description]** at the port-end.
- 10.3 [DP] Boats whose warning signal has not been made shall avoid the starting area during the starting sequence for other races.

*Note: Use this SI only if there are more classes using same starting line.*
- 10.4 If any part of a boat's hull is on the course side of the starting line at her starting signal and she is identified, the race committee will attempt to broadcast on VHF her sail number, bow number or the name of the boat. Delay in the radio broadcast of these calls, or the order in which they are made, or any omission or failure in the transmission or reception of these, will not be grounds for a request for redress by a boat. This changes RRS 61.1(a).

- 10.5 A boat that does not start within **[insert number]** minutes in the inshore races and **[insert number]** minutes in the offshore race(s) after her starting signal will be scored Did Not Start without a hearing. This changes RRS A5.1 and A5.2.

## 11 Change of the next leg of the course

**Inshore races** - To change the next leg of the course, the race committee will lay a new mark and remove the original mark as soon as practicable. If mark 1 is replaced by a new mark, mark 1A will not be replaced and will no longer be a mark of the course for boats after rounding the new mark. When in a subsequent change a new mark is replaced, it will be replaced by an original mark except that mark 1A will not be replaced.

## 12 The Finish

- 12.1 **Inshore races** - The finishing line will be between **[insert description]** and **[insert description]**.
- 12.2 **Offshore races** - The finishing line will be between **[insert description]** and **[insert description]**.
- 12.3 [DP] Boats that finish by night shall illuminate their numbers when finishing, and in case of doubt shall try to identify themselves to the race committee after finishing.
- 12.4 [DP] If the race committee is absent when a boat finishes, she shall report her finishing time, and her position in relation to nearby boats, to the race committee at the first reasonable opportunity.

## 13 Time Limit

- 13.1 **Inshore races:** The Race Time Limit (see RRS 35) will be 2 hours after the starting signal. The Finishing Window is the time for boats to finish after the first boat sails the course and finishes and will be **[insert number calculated as in note below]**.

*Note: Finishing Window shall be calculated using the Time Allowances (TA) for windward/leeward course at 6 kts of wind for the slowest and the fastest boat in a class as follows:*

$$\text{Finishing Window} = 180 \cdot \frac{TA_{\text{slowest boat}} - TA_{\text{fastest boat}}}{TA_{\text{fastest boat}}} \text{ (minutes)}$$

- 13.2 **Long offshore race:** The time limit for each class is 36 hours after the starting time of the respective class. However, if the first boat in each class finishes in 30 hours or more, then the time limit for all other boats in that class is extended to 42 hours.
- 13.3 **Short offshore race:** The time limit for each class is 12 hours after the starting time of the respective class. However, if the first boat in each class finishes in 10 hours or more, then the time limit for all other boats in that class is extended to 14 hours.
- 13.2 **Coastal race:** The time limit for each class is 6 hours after the starting time of the respective class. However, if the first boat in each class finishes in 5 hours or more, then the time limit for all other boats in that class is extended to 8 hours.
- 13.2 The time limit for each class is **[insert number]** hours after the starting time of the respective class. However, if the first boat in each class finishes in **[insert number]** hours or more, then the time limit for all other boats in that class is extended to **[insert number]** hours.

*Note: Time limits shall be calculated based on the length of the course and expected duration of the race.*

- 13.3 Boats failing to finish within the Finishing Window (for inshore races) or their time limit (for offshore races), and not subsequently retiring, penalized, or given redress, will be scored Time Limit Expired (TLE) without a hearing. A boat scored TLE will receive the points of the last boat that finished within its time limit plus one. This changes RRS 35, A5.1, A5.2 and A10.

## 14 Hearing requests

14.1 *Inshore races* - For each class, the protest time limit is **[insert number]** minutes after the last boat in that class finishes the last race of the day or the race committee signals no more racing today, whichever is later. The time will be posted on the official notice board.

*Offshore races* - For each class, the protest time limit is **[insert number]** minutes after protestor's finish or the race committee signals no more racing today, whichever is later. If a boat finishes between **[insert time and date]** and **[insert time and date]** her protest time limit is extended to 09.00 on **[insert date]**.

14.2 Hearing request forms are available from the race office at **[insert URL or location]**.

14.3 Notices to inform competitors of hearings in which they are parties or named as witnesses will be posted

a) *Inshore races* - no later than 30 minutes after the protest time limit

b) *Offshore races* - within 30 minutes of the finish of all the boats involved in the protest, except those notices will not be posted from **[insert day and date of offshore race]** at **[insert time]** until **[insert day and date of offshore race]** at **[insert time]**.

Hearings will be held in the protest room, located at **[insert description]**.

## 15 Scoring

The decision on the scoring method and scoring parameters used will be at the sole discretion of the race committee and together with length of course, directions of leg and the wind direction and speed will not be grounds for request for redress by a boat. This changes RRS 61.1(a).

## 16 Safety regulations

16.1 [DP], [NP] A boat that retires from a race shall notify the race committee at the first reasonable opportunity.

16.2 [DP], [NP] A boat not intending to race shall inform the race office before the scheduled warning signal.

16.3 [DP] Any use of the engine for propulsion purposes for rescuing people, giving help or any other reason shall be reported after arrival in written form to the race committee stating the reasons for such procedure. If a boat does not gain a significant advantage in the race, the international jury may impose a discretionary penalty.

## 17 Replacement of crew or equipment

17.1 [DP] Any crew changes (adding new crew members, replacing or disembarking crew members) shall be notified to the race office no later than **[insert number]** hours before the scheduled time of the start of the first race of the day. Crew changes will be automatically approved provided that:

a) Crew members registered for the first race on a boat shall not be aboard any other competing boat throughout the remainder of the series.

b) The weight of all crew members on board after all crew changes shall not be greater than the maximum and smaller than the minimum as defined in ORC Rule 200.1.

17.2 [DP] Substitution of damaged or lost equipment is not allowed unless authorized in writing by the technical committee. Requests for substitution shall be made to the committee at the first reasonable opportunity, which may be after the race.

## 18 Equipment and measurement checks

18.1 A boat or equipment may be inspected at any time for compliance with the class rules, notice of race and sailing instructions.

18.2 [DP] When instructed by a race official on the water, a boat shall proceed to a designated area for inspection.

## **19 Official vessels**

- 19.1 Official vessels will display an **[insert flag]**. Failure of any official boat to display her flag will not be grounds request for redress by a boat. This changes RRS 61.1(a).
- 19.2 Vessels used by press, photographers, film crews, VIPs etc. are not under the jurisdiction of the race committee. Any action by these boats shall not be ground for request for redress by a boat. This changes RRS 61.1(a).

## **20 Support person vessels**

[DP] Support person vessels shall keep well clear of the starting area and, after the preparatory signal, are not to approach within 100 meters of any competing boat. A breach of this SI may result with a scoring penalty against the boat connected and/or withdrawal of permission to be in the racing area for one or more days.

## APPENDIX 1 - BOW NUMBERS

[DP], [NP] Bow numbers shall be placed as forward as possible

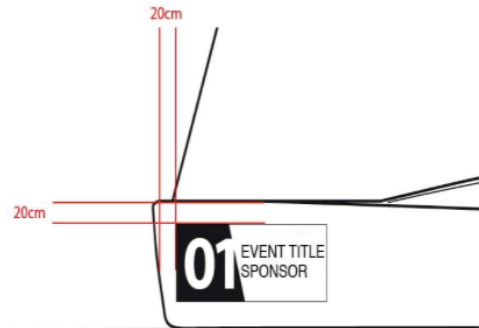
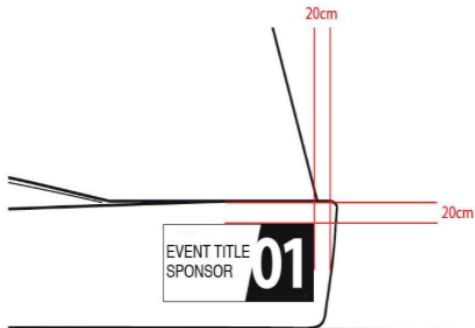

**CORRECT**



**NOT CORRECT**

